

Power supply unit - ESSENTIAL-PS/3AC/24DC/960W/EE - 1018294

Please be informed that the data shown in this PDF Document is generated from our Online Catalog. Please find the complete data in the user's documentation. Our General Terms of Use for Downloads are valid (<http://phoenixcontact.com/download>)



Primary-switched ESSENTIAL POWER power supply for DIN rail mounting, input: 3-phase, output: 24 V DC / 960 W

Your advantages

- ✓ Worldwide use thanks to the wide range input and international approval package
- ✓ Fast installation, thanks to easy DIN rail mounting
- ✓ Greater availability, thanks to fanless convection cooling

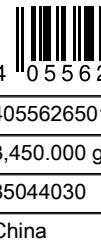

Key Commercial Data

Packing unit	1 pc
GTIN	 4 055626 501796
GTIN	4055626501796
Weight per Piece (excluding packing)	3,450.000 g
Custom tariff number	85044030
Country of origin	China

Technical data

Dimensions

Width	139 mm
Height	130 mm
Depth	190 mm
Installation distances left/right	0 mm
Installation distances top/bottom	50 mm

Ambient conditions

Degree of protection	IP20
Ambient temperature (operation)	-25 °C ... 70 °C (> 55 °C Derating: 2.5 %/K)
Ambient temperature (storage/transport)	-40 °C ... 85 °C
Max. permissible relative humidity (operation)	≤ 95 % (at 25 °C, non-condensing)

Power supply unit - ESSENTIAL-PS/3AC/24DC/960W/EE - 1018294

Technical data

Ambient conditions

Climatic class	3K3 (in acc. with EN 60721)
Degree of pollution	2

Input data

Nominal input voltage range	3x 400 V AC ... 500 V AC
Input voltage range	3x 320 V AC ... 575 V AC
AC frequency range	45 Hz ... 65 Hz
Discharge current to PE	< 3.5 mA
Current consumption	3x 2 A (400 V AC)
	3x 1.6 A (480 V AC)
Nominal power consumption	1149.27 VA
Inrush current	< 20 A
Mains buffering time	> 16 ms (3x 400 V AC)
Recommended breaker for input protection	10 A ... 16 A (UL: 20 A)
Type of protection	Transient surge protection
Protective circuit/component	Varistor

Output data

Nominal output voltage	24 V DC $\pm 1\%$
Setting range of the output voltage (U_{Set})	22.5 V DC ... 29.5 V DC (> 24 V DC, constant capacity restricted)
Nominal output current (I_N)	40 A ($U_{OUT} = 24$ V DC)
Derating	55 °C ... 70 °C (2.5%/K)
Connection in parallel	Yes, for redundancy and increased capacity
Feedback voltage resistance	35 V DC
Protection against overvoltage at the output (OVP)	< 35 V DC
Active current limitation	approx. 42 A
Residual ripple	< 20 mV _{PP}
Output power	960 W
Typical response time	< 1 s
Peak switching voltages nominal load	< 40 mV _{PP}
Maximum power dissipation in no-load condition	11 W
Power loss nominal load max.	87 W

General

Net weight	3.2 kg
Operating voltage display	Green LED
Efficiency	91.5 % (at 400 V AC and nominal values)
Insulation voltage input/output	3 kV AC (type test)
	1.5 kV AC (routine test)
Insulation voltage output / PE	500 V DC
Protection class	I (with PE connection)
Degree of protection	IP20

Power supply unit - ESSENTIAL-PS/3AC/24DC/960W/EE - 1018294

Technical data

General

MTBF (IEC 61709, SN 29500)	> 700000 h
----------------------------	------------

Connection data, input

Connection method	Screw connection
Conductor cross section solid min.	0.2 mm ²
Conductor cross section solid max.	6 mm ²
Conductor cross section flexible min.	0.2 mm ²
Conductor cross section flexible max.	4 mm ²
Conductor cross section AWG min.	22
Conductor cross section AWG max.	10
Stripping length	8 mm

Connection data, output

Connection method	Screw connection
Conductor cross section solid min.	0.5 mm ²
Conductor cross section solid max.	16 mm ²
Conductor cross section flexible min.	0.5 mm ²
Conductor cross section flexible max.	10 mm ²
Conductor cross section AWG min.	8
Conductor cross section AWG max.	6
Stripping length	10 mm

Standards and Regulations

Electromagnetic compatibility	Conformance with EMC Directive 2014/30/EU
Noise emission	EN 55011 (EN 55022) Class B
Noise immunity	EN 61000-6-2:2005
Standards/regulations	EN 61000-4-2
Contact discharge	4 kV (Test Level 2)
Standards/regulations	EN 61000-4-3
Frequency range	80 MHz ... 1 GHz
Test field strength	10 V/m
Frequency range	1.4 GHz ... 2 GHz
Test field strength	3 V/m
Standards/regulations	EN 61000-4-4
Comments	Criterion B
Standards/regulations	EN 61000-6-3
	EN 61000-4-6
Frequency range	0.15 MHz ... 80 MHz
Voltage	10 V (Test Level 3)
Standards/regulations	EN 61000-4-11
Low Voltage Directive	Conformance with LV directive 2006/95/EC
Standard - Electrical safety	EN 60950-1

Power supply unit - ESSENTIAL-PS/3AC/24DC/960W/EE - 1018294

Technical data

Standards and Regulations

Standard – Safety extra-low voltage	EN 60950-1 (SELV)
UL approvals	UL/C-UL listed UL 508
Shock	15g
Vibration (operation)	< 15 Hz, amplitude ±2.5 mm (according to IEC 60068-2-6)
	15 Hz ... 150 Hz, 2.3g, 90 min.
Approval - requirement of the semiconductor industry with regard to mains voltage dips	SEMI F47 - 0706 (200 V AC)

Environmental Product Compliance

REACH SVHC	Lead 7439-92-1
------------	----------------

Drawings

Block diagram

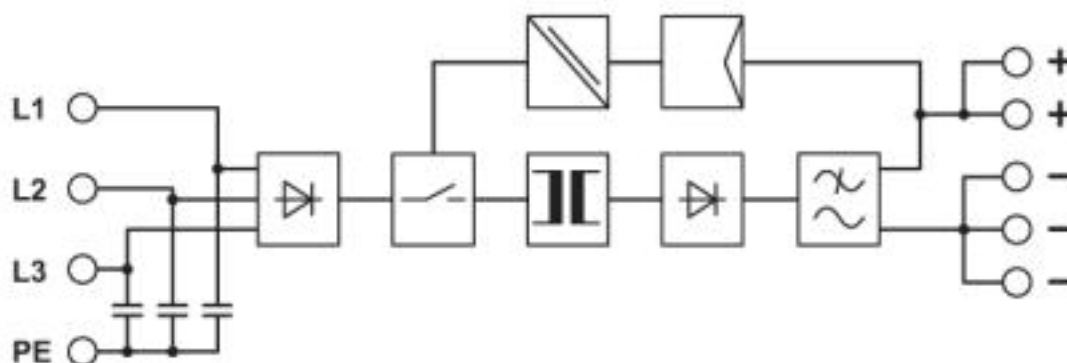

Diagram

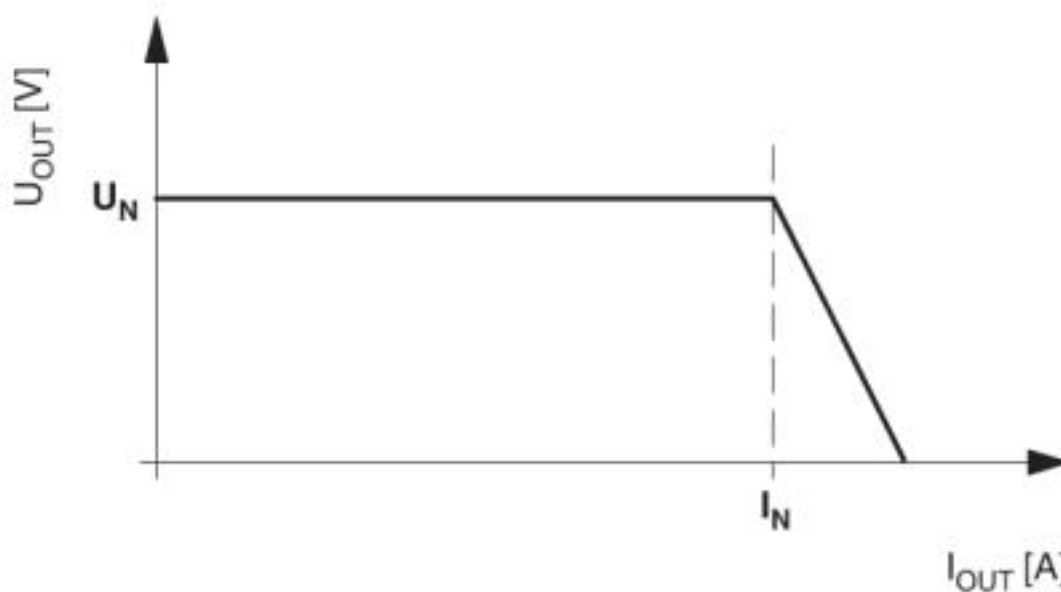

Power supply unit - ESSENTIAL-PS/3AC/24DC/960W/EE - 1018294

Diagram

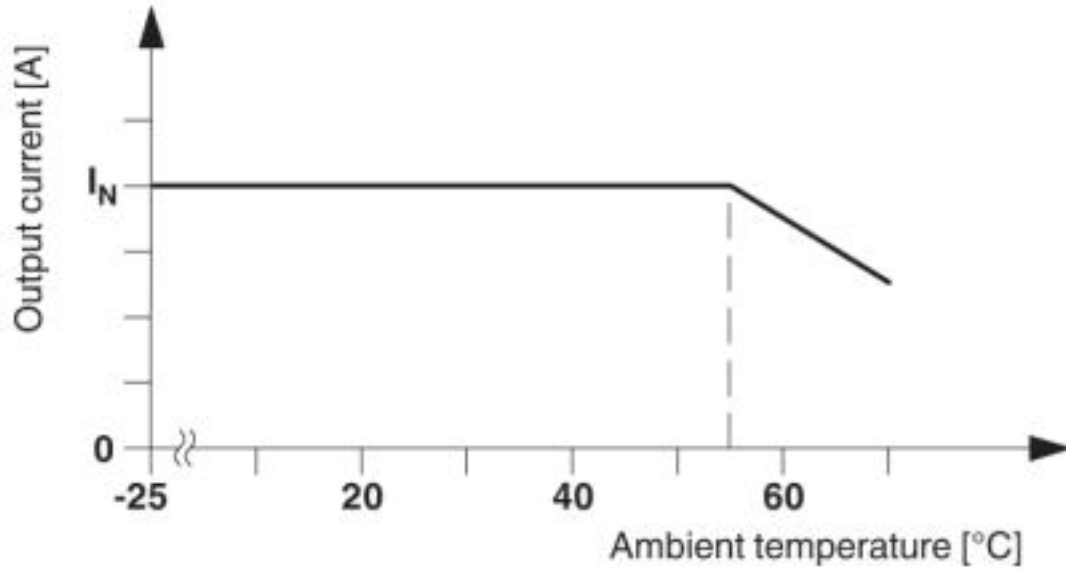

Dimensional drawing

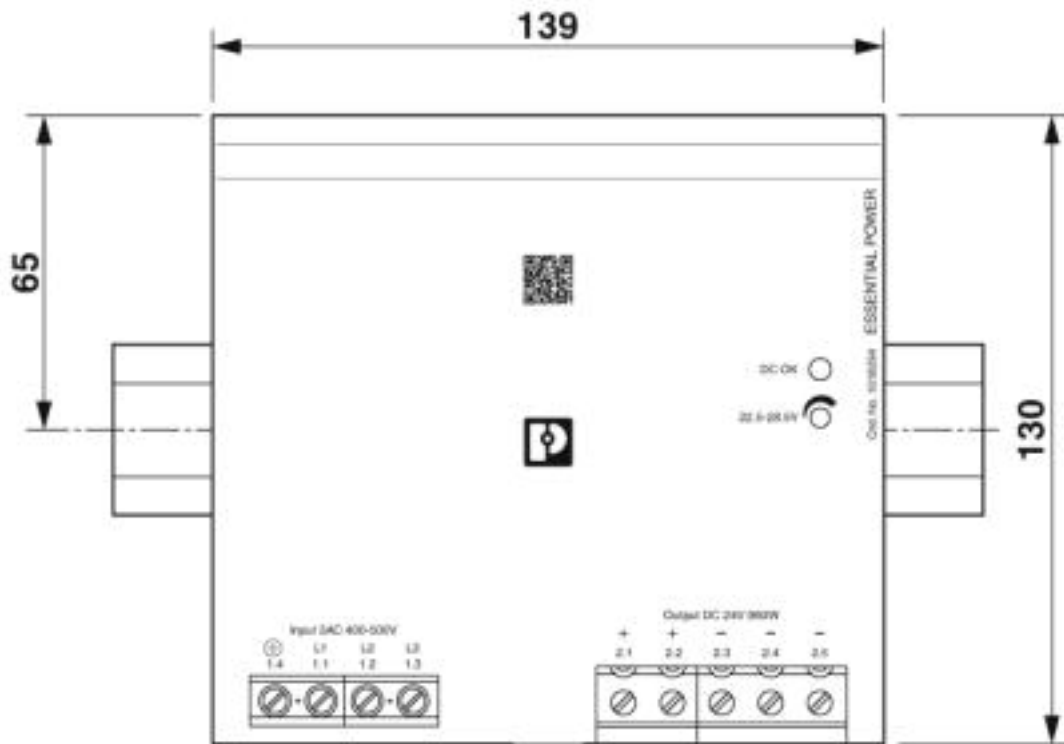

Power supply unit - ESSENTIAL-PS/3AC/24DC/960W/EE - 1018294

Dimensional drawing

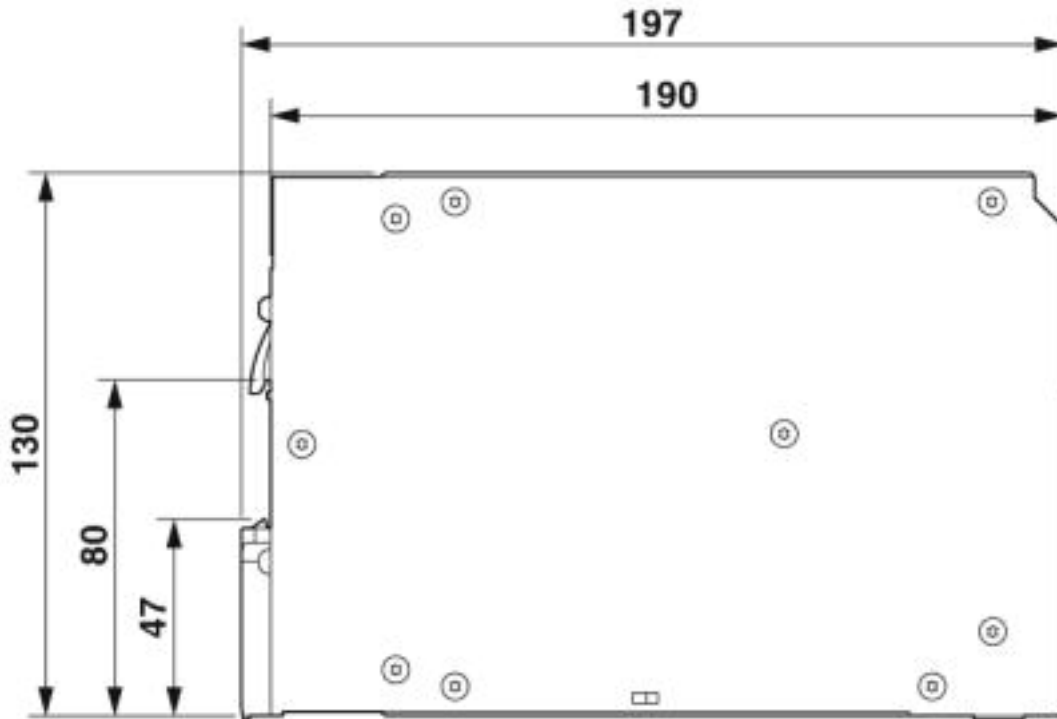

Schematic diagram

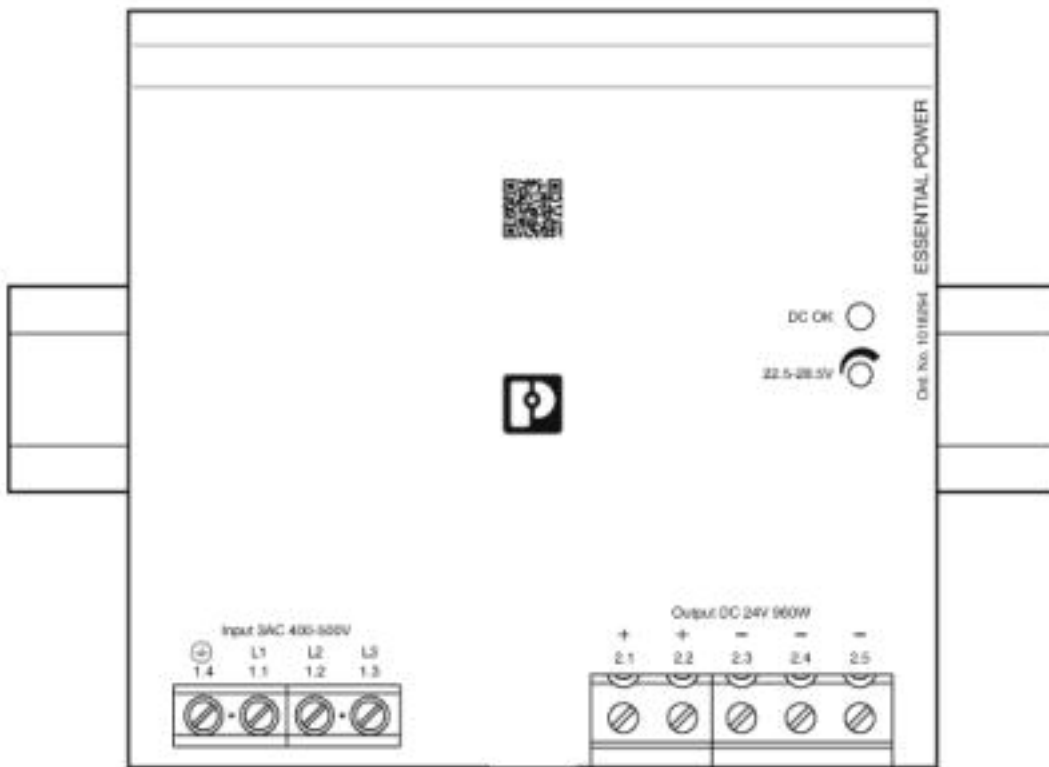

Power supply unit - ESSENTIAL-PS/3AC/24DC/960W/EE - 1018294

Schematic diagram

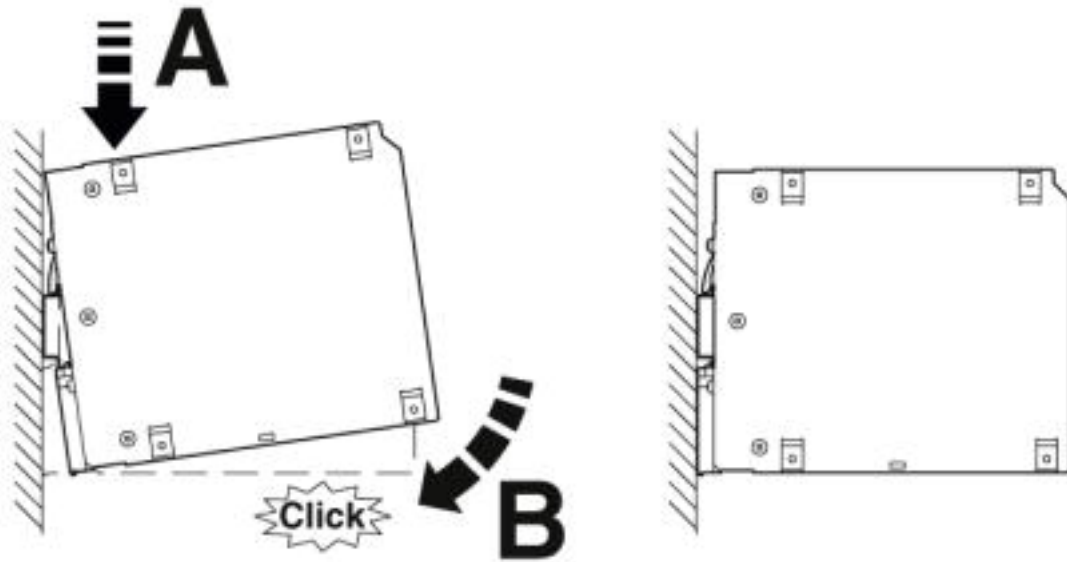

Schematic diagram

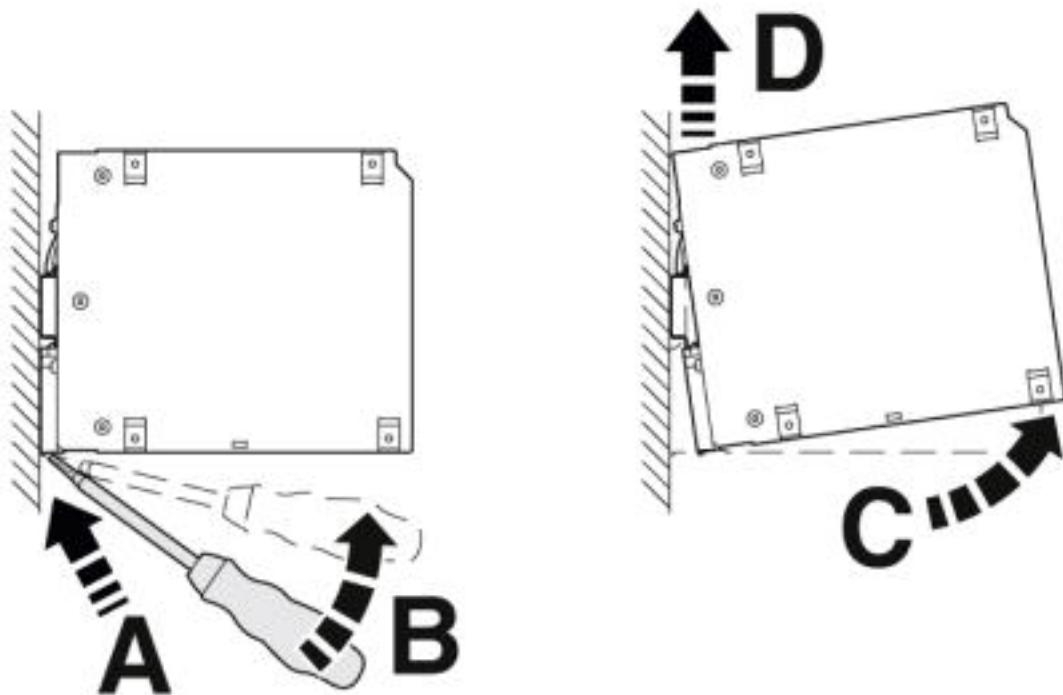

Classifications

eCl@ss

eCl@ss 6.0	27049000
eCl@ss 7.0	27049002

Power supply unit - ESSENTIAL-PS/3AC/24DC/960W/EE - 1018294

Classifications

eCl@ss

eCl@ss 9.0	27040701
------------	----------

ETIM

ETIM 6.0	EC002540
ETIM 7.0	EC002540

Approvals

Approvals

Approvals

EAC

Ex Approvals

Approval details

EAC		EAC*DE*08*02578
-----	--	-----------------

Accessories

Accessories

Device protection

Type 3 surge protection device - PLT-SEC-T3-3S-230-FM - 2905230



Plug-in device protection, according to type 3/class III, for 3-phase power supply networks with separate N and PE (5-conductor system: L1, L2, L3, N, PE), with integrated surge-proof fuse and remote indication contact.

Type 3 surge protection device - PLT-EE-T3-24-FM - 2910540



Pluggable device protection, according to type 3/Class III, for 1-phase power supply networks with separate N and PE (3-conductor system: L1, N, PE) with remote indication contact.

